

INSTALLATION INSTRUCTIONS FOR 307020897 UNIVERSAL REAR ENTRY WEATHER BRAKE

Listed below are the parts required for the installation of the Universal Weather Brakes. Carefully read the instructions, layout parts and study the diagrams before starting installation. Follow the steps as numbered for proper installation.

FIGURE 1 (On page 4)

2 ea	710242501	Front Support
1 ea	710242083	Front Tube
2 ea	710242401	Axle Strap
2 ea	710242301	Axle Bracket
2 ea	710242183	Front Tube Ext.-24
2 ea	290006400	Suction Cups
2 ea	710242701	Cinch
1 ea	710242601	Suction Retainer
2 ea	710241901	Flat Rod
2 ea	710242283	Rear Upright-31 3/4"

SMALL PARTS LIST

4 ea	201303000	F2 Clips
8 ea	202040483	Spring Coil
8 ea	202621183	U Bolt
21 yd	205370201	Webbing
2 ea	290006400	Suction Cups
4 ea	202621583	Bolt 3/8-16 x 9
2 ea	292020183	Bolt 1/4-20 x .75
6 ea	292020483	Bolt #10-24 x .50
2 ea	292020783	Bolt 1/4-20 x 1.00
8 ea	292021083	Bolt #10-24 x .75
4 ea	292021583	Bolt 1/4-20 x 1.50
22 ea	292507983	Nut 1/4-20
14 ea	292508183	Nut #10-24
4 ea	292508083	Nut 3/8-16
6 ea	712190181	F1 Clips

- Slide # 710242083 Front Tube into top hem of cover and # 710242183 Front Tube Extensions into wide hem on right and left side of cover. Attach tubes using 1/4" x 1 1/2" bolts and nuts.
- Place cover over tractor. Loosely bolt #710242501 front supports to front tubes using U bolts. Space supports so suction cups will be in contact with flat surface of hood.
- Bolt # 710242601 retainer and suction cups to supports using 1/4" x 3/4" or 1/4" x 1" bolts. Support goes between suction cups and retainer.
- Bolt # 710242283 rear uprights to # 710242301 axle brackets using U bolts. Bolt axle brackets to axle with 3/8" x 9" bolts and nuts. Use # 710242401 axle straps under axle. Adjust tube frame for height and back/forth placement. Bolt #710242283 rear uprights to #710242183 front tube ext. with U bolts.
- TIGHTEN ALL NUTS AND BOLTS AT THIS TIME.**
- Thread a piece of cloth strap through the end of #710242601 retainer (figure 1). Tie a knot in the strap so it will not pull back through the hole. Thread the other end through #710242701 cinch, down around a handle, frame or object on tractor and tie to other hole in cinch. Repeat for other side. Adjust both cinched to hold suction cups tightly on the tractor.
- Straighten cover to front of tractor to fit length and fold over excess (see figure 2). Place #710241901 flat strap in between the fabric layers. Cut slits in the fabric layers and place 3/16" x 1/2" bolts through fabric layers and strap. Repeat on other side.
- Cut 2 slits in cover in back of #710241901 flat strap approx. 5" from top & bottom and fasten springs and cloth straps. Bring both straps around front of tractor. Cut 2 slits in cover (same as other side) thread strap thru slits. Adjust tension, tie knot. (See Figure 3)
- For tractors that have exhaust pipes, etc. that extend outside of hood it may be necessary to provide a guard to protect the cover. **GUARD IS NOT PROVIDED, MAKE FROM SHEET METAL.**
- For straps over hood and under tractor tie cloth straps to springs. Hook spring to grommets on one side of motor cover and route to other side of motor cover. Adjust tension and tie knot. (See Figure 3)



11. Assemble 3 windows by cutting slits close to rod inside of hem. Using F-1 clips and 3/16" x 3/4" bolts attach the two side windows to the center windshield. **(See figure 4).**
12. Insert the F-1 clips in lower windshield frame. Put on tractor and use F-2 clips around front tube of cab frame.
13. Bolt F-1 & F-2 together using 3/16" x 3/4" bolts and nuts.
14. Slide F-2 clips around cab frame & bolt to side windows using 3/16" x 3/4" bolts.
15. Motor sides may be rolled back to release excess heat. Simply unhook 2 front springs and roll sides back and tie web strap around roll through grommet in fabric.

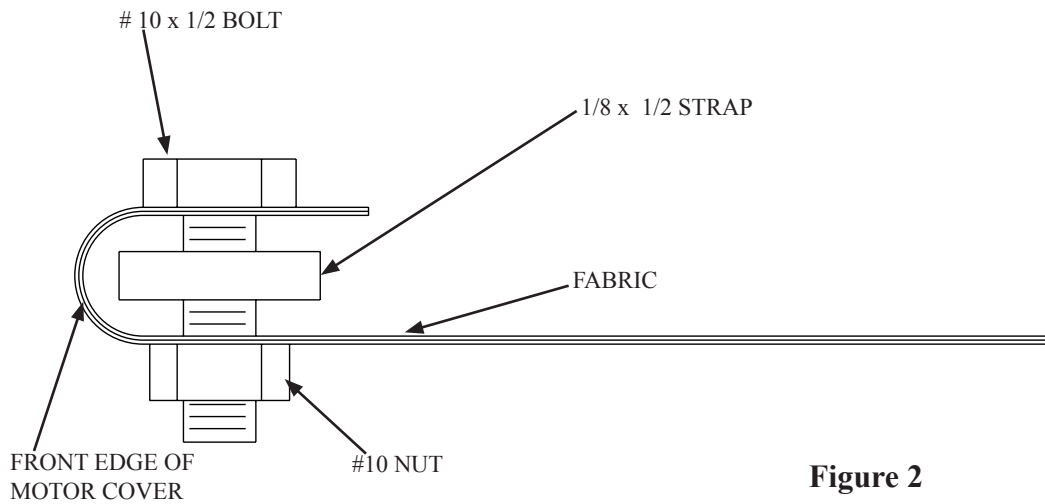

286022100_fig3.pdf

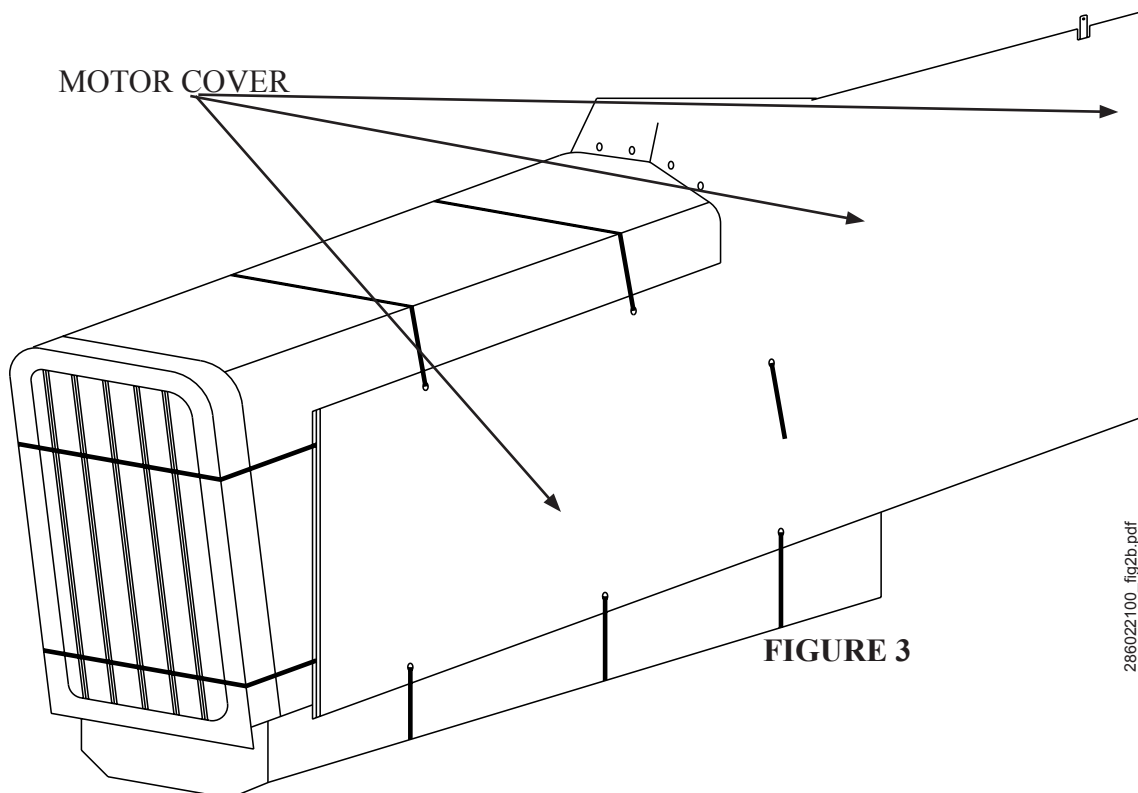

286022100_fig2b.pdf

STEP 11

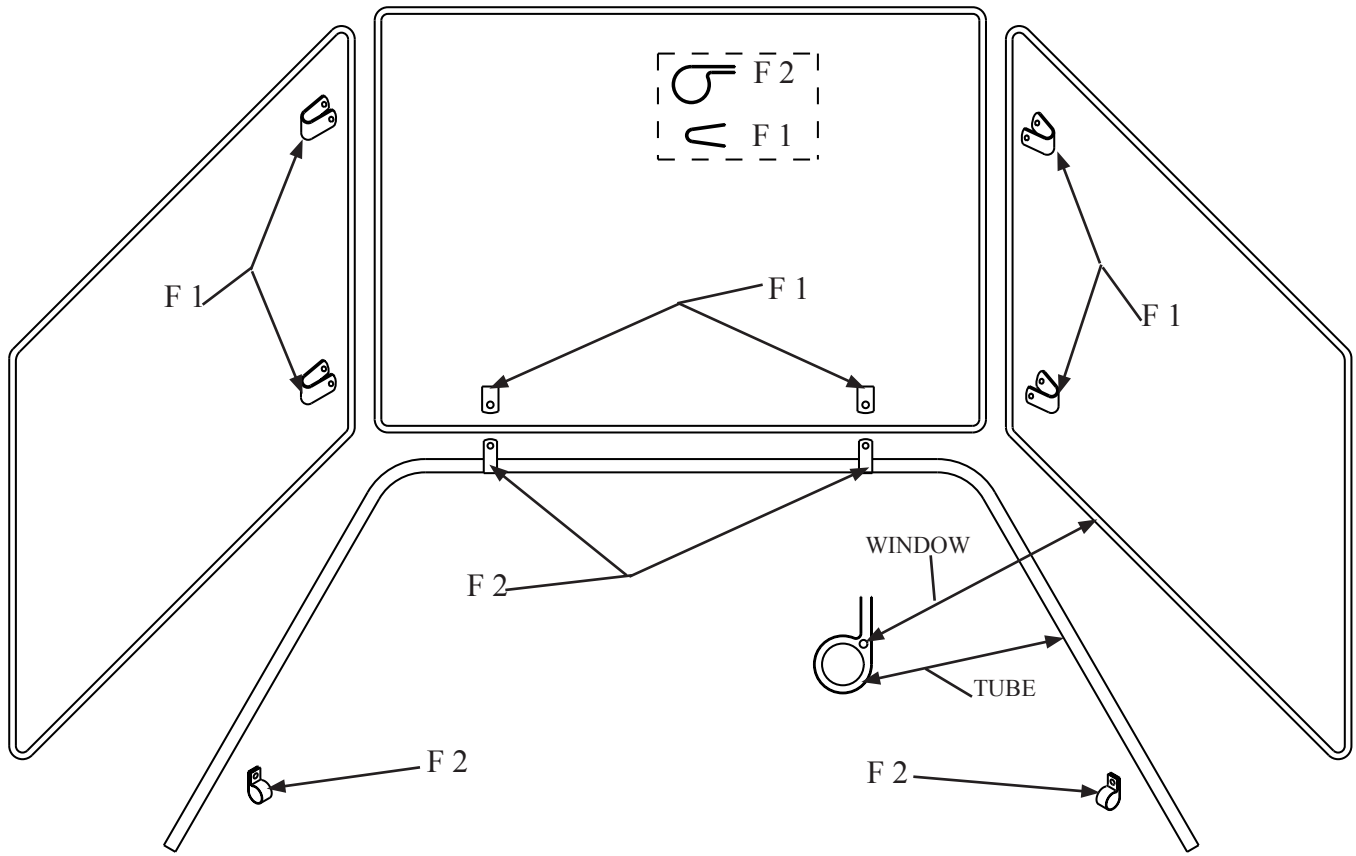

FIGURE 4

286022100_fig5.pdf

FIGURE 1

