

# INSTALLATION INSTRUCTIONS

## FOR

# 307020895, 307020896, 307602283 & 307602284

# FEMCO UNIVERSAL WEATHER BRAKES

## LARGE & SMALL SIDE ENTRY MODELS

Listed below are the parts required for the installation of the Universal Weather Brakes. Carefully read the instructions, layout parts and study the diagrams before starting installation. Follow the steps as numbered for proper installation.

- 2 - #710242501 Front Support
- 1 - #710242883 Front Tube
- 1 - #710243101 Latch
- 1 - #710243001 Door Post
- 2 - #290006400 Suction Cups
- 2 - #710242701 Cinch
- 1 - #710242601 Suction Retainer
- 2 - #710241901 Flat Rod
- 1 - #710242983 Rear Upright

### SMALL PARTS:

201303000	F2 Clip	6
202040483	Spring Coil	8
202621183	U Bolt	4
205370201	Webbing, (ft)	21
290006400	Suction Cup	2
292020183	Bolt, 1/4-20 x .75	4
292020483	Bolt, #10-24X .50	6
292020783	Bolt, 1/4-20 x 1.00	4
292021083	Bolt, #10-24 x .75	10
292021583	Bolt, 1/4-20 x 1.50	2
292507983	Nut, 1/4-20	16
292508183	Nut, #10-24	16

1. Slide #710242883 front tube into top hem of cover and #710242983 rear upright into wide hem on right side of cover. Bolt tubes together using 1/4" x 1" hex head bolts and nuts.
2. Place cover over tractor. Loosely bolt #710242501 front support to front tube using U-bolts. Space supports so suction cups will be in contact with flat surface of hood.
3. Bolt #710242601 retainer and suction cups to supports using 1/4" x 3/4" or 1/4" x 1" bolts. Support goes between suction cups and retainer.

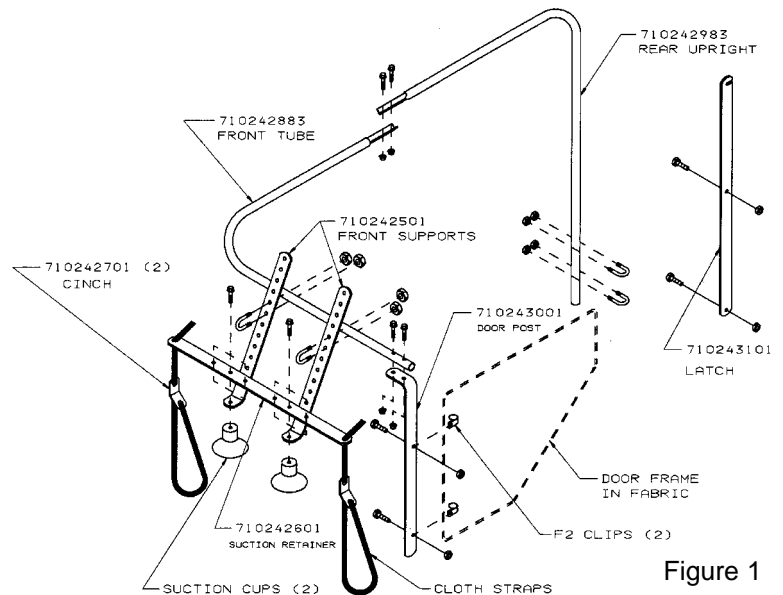

Figure 1

4. Adjust tube frame for height and back/forth placement. Then drill 9/32" holes, each side of #710242983 rear upright, 1" apart.
5. In right fender, bolt #710242983 rear upright to fender with 2 U-bolts and nuts.
6. **TIGHTEN ALL NUTS AND BOLTS AT THIS TIME.**
7. Thread a piece of cloth strap through the end of #710242601 retainer (Figure 1) Tie a knot in the strap so it will not pull back through the hole. Thread the other end through a #710242701 cinch, down around a handle, frame or object on tractor and tie to other hole in the cinch. Repeat for other side. Adjust both cinches to hold suction cups tightly on the tractor.

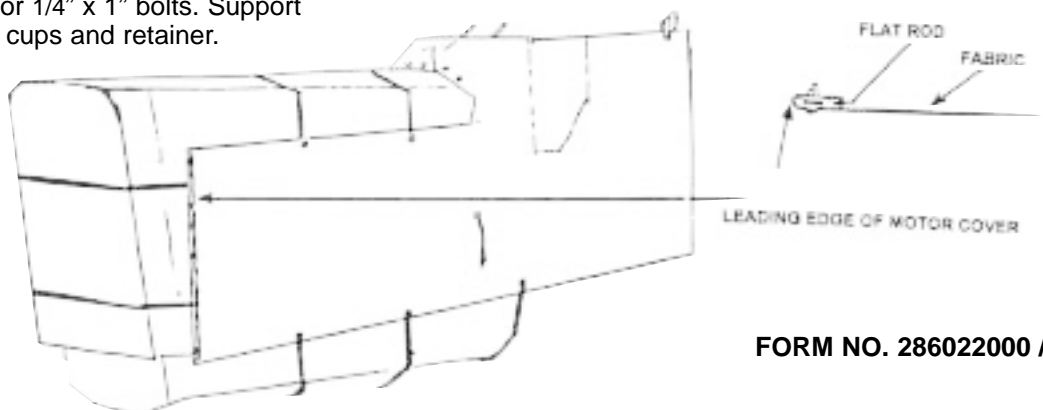

Figure 2

8. Bolt #710243001 door post to #710242883 front tube with 1/4" x 1 1/2" bolts and nuts. **TIGHTEN NUTS AND BOLTS.**
9. Position door in cover to door post, mark location of holes in door post to door in cover. Cut (2) 5/8" slits in door cover to match holes in door post. Bolt door frame in cover to door post using 3/16 x 3/4 bolts, nuts, and F2 clips.
10. Tie short cloth strap loop through grommet in left rear edge of cover. Place #710243101 latch on inside of fender and hook loop of web in notch of latch. Drill holes in fender and bolt latch using 1/4" x 3/4" bolts.
11. Straighten cover to front of tractor to fit length and fold over excess (see Figure 2). Place #710241901 flat rod in between the fabric layers. Cut slits in the fabric layers and place 3/16" x 1/2" bolts through fabric layers and rod. Repeat on other side.
12. Cut 2 slits in cover in back of #710241901 flat strap approx. 5" from top & bottom and fasten springs and cloth straps. Bring both straps around front of tractor.

Cut 2 slits in cover (same as other side) thread strap thru slits. Adjust tension, tie knot..

13. For tractors that have exhaust pipes, etc. that extend outside of hood it may be necessary to provide a guard to protect the cover. **GUARD IS NOT PROVIDED, MAKE FROM SHEET METAL.**
14. Tie cloth strap to spring. Hook spring to grommet (top & bottom) and route to other side. Adjust tension and tie knot.
15. Assemble 3 windows by cutting slits close to rod inside of hem. Using F-1 clips and 3/16" x 3/4" bolts attach the two side windows to the center windshield. See figure 4.
16. Insert the F-1 clips in lower windshield frame. Put on tractor and use F-2 clips around front tube of cab frame.
17. Bolt F-1 & F-2 together using 3/16" x 3/4" bolts and nuts.
18. Slide F-2 clips around cab frame & bolt to side windows using 3/16" x 3/4" bolts.

Motor sides may be rolled back to release excess heat. Simply unhook 2 front springs and roll sides back and tie web strap around roll through grommet in fabric.

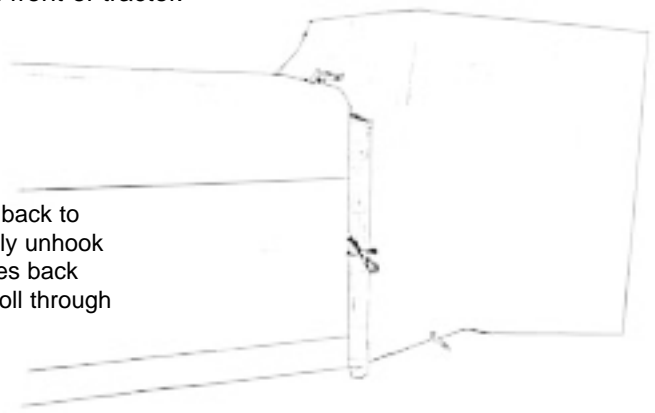

Figure 3

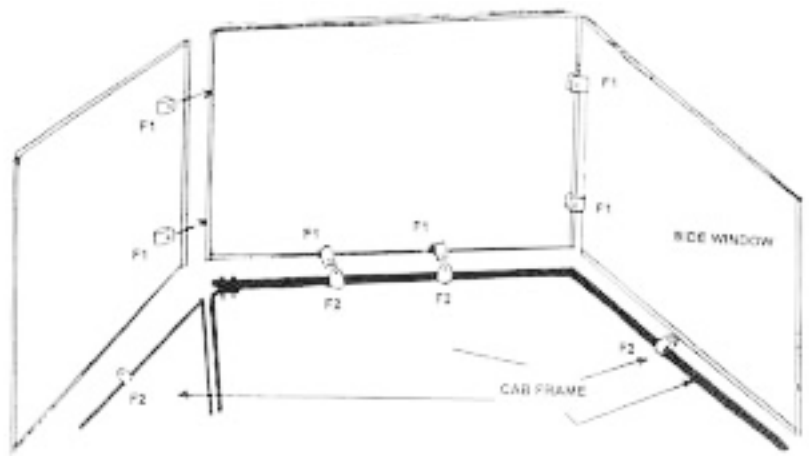
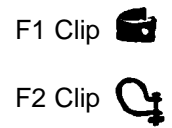

Figure 4



**GENERAL OFFICES**  
 500 North 81 ByPass  
 McPherson, KS 67460  
 Phone: (316) 241-3513  
 FAX: 1-316-241-3532  
 Toll Free: 1-800-677-0898

*Subsidiaries*  
 HINSON-FEMCO  
 FEMCO PLASTICS